

## LIVESTOCK RF IDENTIFICATION AND MANAGEMENT – PART I: 13,56 MHz RFID SYSTEM

**Valentin POPA, Toader STRUGARIU, Catalin SIICU, Eugen COCA**

*"Stefan cel Mare" University of Suceava  
str. Universitatii nr.9, RO-720225 Suceava  
valentin@eed.usv.ro*

**Abstract.** *This paper is proposing a new 13,56 MHz RFID transponder based system for animal identification and tracking. The present barcode and 125/134 kHz transponder based systems are presented and compared with the performances of the new 13,56 MHz RFID system. The paper underlines the mainly benefits for the new system: read/write procedures, larger operating range and shorter read/write time. The special transponder coil label attached to the animal's tag is designed. A management program for livestock identification and tracking will be presented in the part II of this paper.*

**Keywords:** *transponder, livestock, RFID, management, identification, tracking, animal.*

### 1. Introduction

The legislative and procedure harmonization in the veterinary and zootechnic fields between Romania and European Union represents one of the major criteria for integration in the European structures, in agriculture domain. Livestock identification, registration and animal origin recording become few very important activities in order to manage the zootechnic sector, animal tracking and their health. According with all these goals, the government issued few specific laws for cattle, sheep, hogs or horses identification and the in-field recording and the traceability tracking process started already.

The most implemented electronic identification systems in livestock area are barcode systems and Radio Frequency IDentification (RFID) systems [1]. Electronic identification systems for animals have been used for almost 20 years in USA and Australia and are now state of the art in Europe. Nowadays, these systems are used for tracing the origin of animals, for the control of epidemics, diseases and treatments applied to the animal, for automatic feeding and productivity calculating in modern farms, etc.

The barcode system is based on a printed binary code comprising a field of bars and gaps, arranged in a parallel configuration representing data. An optical laser scanner reads this bars and gaps configuration.

In a RFID system, data is stored on an electronic data-carrying device – the transponder. The transponder is functioning by replying to an interrogation request received from a reader, mainly by returning some data stored in the transponder memory such as an identity code or the value of a measurement.

In Romania, the electronic identification and tracking systems started to be implemented since 2003 for a limited number of applications (access control, items and persons identification). In the zootechnic field, for cattle, sheep and hogs identification, a barcode based system is proposed. For example, in cattle case, a tag with a barcode ID number will permanently be mounted in the ear of the animal. On the other hand, a special injectable transponder based tag is proposed for horse identification.

Basing on the present barcode based system, this paper will introduce a 13,54 MHz RFID system in order to improve the livestock identification and management. The new system will not exclude the former one but it will improve it, working together.

### 2. RFID systems

A RFID system is always made up of two components: the transponder and the interrogator or reader. The block diagram for a RFID system is depicted in figure 1. The

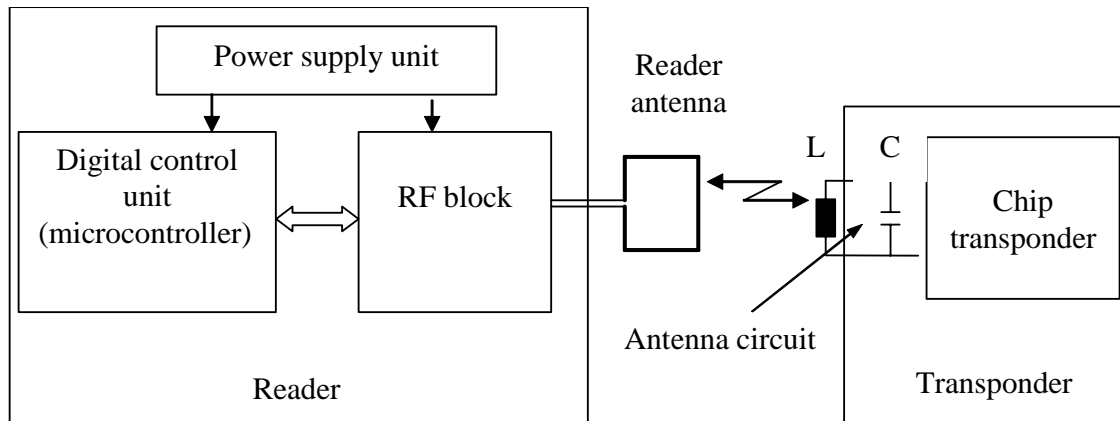

**Figure 1.** The block diagram for a RFID system

equipment usually named *reader* can be a read or even a read/write device, depending upon the design and technology. The transponder is composed by a chip transponder and an antenna circuit (a coil  $L$  and an equivalent capacitor  $C$ ). The equivalent capacitor  $C$  can be an internal capacitor (realised on the same chip with the transponder chip), an external capacitor or a combination between these two variants. In all variants, the designer will include in  $C$  the parasitic capacitance also. All transponder functions are under reader control.

The transponders used in identification systems are usually classified depending of the coupling type between reader and transponder. There are inductively coupled, electrically coupled and electro-magnetically coupled transponders.

The inductively (magnetic) coupled transponders, also classified in proximity and vicinity transponders, are still the most common transponders available today on the RFID market [2]. Generally they are operating at frequencies typically in the order of 125/134 kHz for proximity transponders and 13,56 MHz for vicinity transponders. These transponders are characterised by antenna systems that comprise of numerous turns of a fine wire around a coil former to collect energy from reader's electromagnetic field, using the magnetic component. Due to the magnetic method of coupling, range is limited generally to 1-2 cm for proximity transponders and up to 25 cm for vicinity transponders. However, the maximum range reported by producers is around 2 m, using a high gain reader antenna and only for 13,56 MHz transponders. The 125/134 kHz

inductively coupled transponders are still the only transponders used in livestock electronic identification systems nowadays.

Electric field coupled transponders [3] generally provide vastly increased ranges over their magnetic counterparts. Efficient electric field propagation requires antenna systems that are typically half a wavelength of the operating frequency in size. This causes practical limits for the lowest frequency due to the size of the antenna. Higher operating frequencies require more expensive components and loose the ability to transfer energy at a rate of the inverse of the wavelength squared. In addition, the energy density of a signal radiated using electric field coupling, decreases as the inverse of the distance squared between the source and the transponder. Whereas sensitive receivers can compensate for this loss of energy for the data communications over long distances, passive transponders which use the reader's energising field as a source of power are practically limited to about ten meters.

One very important feature of RFID systems is the power supply to the transponder. Passive transponders do not have their own power supply. The whole required power for operation must be drawn from the electromagnetic field of the reader. Both components, electric and magnetic, could be used by transponder. Active transponders incorporate a battery, which supplies a part of the power for operation (generally for microcontroller operation only, but not for data transmission via electromagnetic field for which the reader electromagnetic field is still used).

In the simplest and the cheapest variant, the transponder can have only one bit memory and they are mainly used in EAS (Electronic Article Surveillance), in anti-thief systems. Then, in very simple identification systems, the reader can only read the transponder and the data record, usually one unique serial number, is performed when the chip transponder is manufactured. Nowadays, there has been an enormous upsurge in the popularity of writable transponders. In this case, the reader can also write new data in transponder.

RFID systems operate according with full duplex, half duplex and sequential procedures. For full and half duplex procedures the transfer of energy from reader to the transponder is continuous, while, in sequential procedure, the transfer of energy is interrupted during data transmission from transponder to the reader. The data transmission specifications and coding procedure are provided by two important standards: ISO 14443 for proximity coupling systems and ISO 15693 for vicinity coupling systems.

### 3. Transponders used in livestock identification systems

There are four basic procedures for attaching the transponder to the animal: collar transponder, ear tag transponder, injectable transponder and bolus transponder.

Collar transponders can be easily transferred from one animal to another and possible applications are automatic feeding and milk output record. This version is not dedicated to store data during the whole life of the animal.

Ear tags are incorporating an inductive coupled transponder compete with the much cheaper barcode ear tags. But, beside of low range, the latest cannot store more than one serial number and is not suitable for automation. Ear tags are not suitable for horses but can be used for cattle, sheep and hogs and it will be carried during whole life.

Both collar and ear tags are usually using the most common construction format, the so-called disk. The transponder is mounted in a round

injection moulded housing, with a diameter from a few mm to 5 or 6 cm. This format is the most used one in RFID cattle identification nowadays.

Injectable transponders are using transponders in a sterile glass package (figure 2) and are introducing under the animal skin with an injection needle. In this case, a glass tube of 10-30 mm contains a chip transponder, mounted on a small PCB, a chip capacitor and a coil for the resonant circuit. Fine copper wires wound onto a

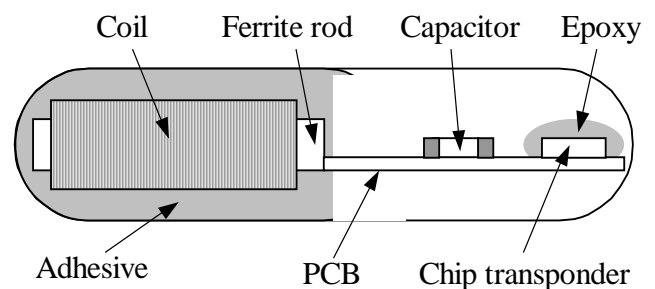
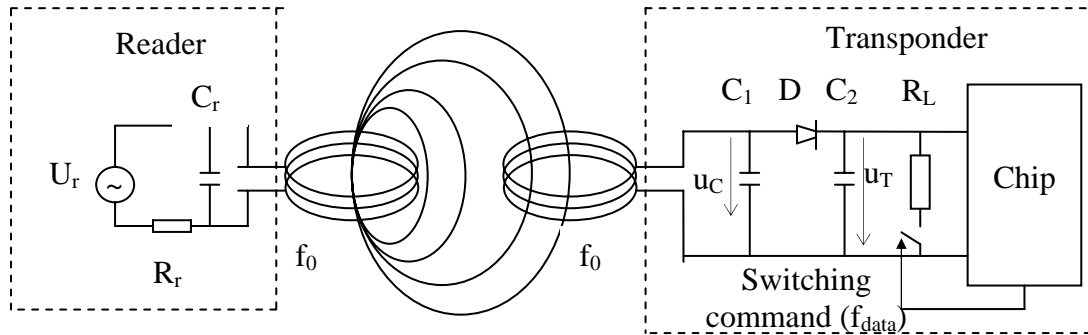

**Figure 2.** Mechanical layout of a glass transponder

ferrite rod make the transponder coil (figure 2). This version is mainly used for horses and pets identification. A disadvantage appears because the transponder represents a foreign body in the animal's tissues, it can lead to problems in the locational stability within the animal's body and may cause problems when reading the transponder. A special advantage is the possibility of the animal's body temperature measuring.

The bolus is a transponder mounted in an acid resistant, cylindrical housing, which may be made of a ceramic material. The bolus is deposited in the rumen. The injected transponder and bolus are the only foolproof identification systems available to stock keepers. Beside of ear tags, this version is much more sure against the accidents that lead to transponder's destruction.

The specific frequencies used in livestock identification systems are 134 KHz in USA and Australia and 125 kHz in Europe. This paper will introduce the first 13,56 MHz RFID system for livestock tracking and management. The operating principle of a passive inductively coupled transponder used in this new system is depicted in figure 3.



**Figure 3.** The operating principle of a passive inductively coupled transponder

The reader's antenna equivalent circuit is composed by a  $C_r$  capacitor and a reader's coil inductance forming a parallel resonant circuit with a resonant frequency that corresponds with the transmission frequency  $f_0$ . This antenna generates an electromagnetic field and because of the short distance between reader and transponder, a small part of the emitted field penetrates the transponder's coil area and a voltage  $u_C$  is generated by inductance. This voltage is rectified with diode  $D$  and serves as power supply  $u_T$  for chip transponder (microcontroller). On the other hand,  $C_1$  and the antenna coil of the transponder form a resonant circuit tuned to the transmission frequency of the reader. The voltage  $u_C$  at the transponder reaches a maximum due to resonance step-up in the parallel resonant circuit.

So, if a resonant transponder is placed within the magnetic alternating field of the reader's antenna, the transponder draws energy from this magnetic field. The resulting feedback of the transponder on the reader's antenna can be represented as equivalent transformed impedance in the antenna coil of the reader. Switching a load resistor  $R_L$  on and off at the transponder's antenna therefore brings about a change in this transformed impedance. The switching is under chip transponder control and it can be according with transmitted data (frequency  $f_{data}$  - see figure 3). This has effect of an amplitude modulation of the voltage of reader antenna and this modulation can be used for data recovery. This type of data transfer is called load modulation and is exhaustively described in [1]. In practice, the data transfer is often realised by load modulation with subcarrier, by switching the load resistor from transponder with a frequency  $f_s < f_0$  ( $f_s > f_{data}$ ). Two modulation

sidebands appear at the reader input circuit around  $f_0 - f_s$  and  $f_0 + f_s$  frequencies that are much more easier to be separated and used for data recovery.

#### 4. The system presentation

In order to design a RFID system for livestock identification and tracking, we have to take in consideration that the animals do not stay on one site but moves through several places. This means that different readers may be involved in collecting data from the same animal transponder. The communication protocol was standardised by the ISO 11784/11785. But these standards offer a read only protocol to read the unique number of the animal transponder. This number is stored in a central database, which contains all addition information on the animal. The same situation is found in the barcode system, the differences between these two systems are the reader type and the method to store de unique number on the animal's tag.

As application requirements became increasingly complex, users want to access the animal's data directly from the transponder without having to contact the database. To meet these new requirements we need to use transponders with memory and a read/write protocol. Even if it is not yet applicable on livestock identification systems, the communication with transponders working on 13,56 MHz are already standardised by ISO 14443 and ISO 15693.

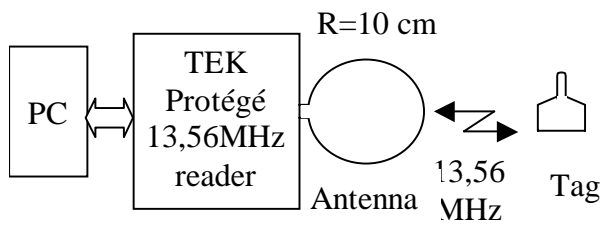

**Figure 4.** The components of a 13,56 MHz identification system



**Figure 5.** The tag used in barcode system



**Figure 6.** The label transponder attached to the animal's tag.

The main components of the 13,56 MHz RFID proposed system are presented in figure 4. The proposed RFID system will not replace the present barcode based system already introduced in Romania, but will improve it. The tag with a barcode label proposed to improve the actual system should be realised in a form presented in figure 5.

Using the format from figure 5, we are proposing to attach a label format transponder on the backside of this tag. This label consists of a paper or plastic foil onto which the transponder coil and transponder chip is applied. After attachment to the tag, the label can be laminated or lacquered for protection against scratches or moisture. We have tested the system using a self-adhesive label with 44x44 mm size and a Philips SLI ISO 15693 transponder [4] attached like in figure 6.

for example). On the other hand, there are already readers on the market that can read transponders and barcode label also. We used a TEK Protégé 13,56 MHz reader with a 10 cm circular antenna. The 44x44 mm transponder antenna size is not optimized from the read/write range point of view. The backside tag area is larger than that and we have to design an

optimum transponder antenna for an optimum operating range of the system.

The PC unit from figure 4 contains the central database updated both by operator and mobile readers with all recorded data from animal's transponders. A software livestock management program will be stored on this computer.

## 5. The label transponder design

We designed an optimum label format for the transponder antenna from the maximum available tag size point of view. The transponder coil is created using the etching technique. This technique is the standard procedure for the manufacture of printed circuit boards. A copper foil of about 0,05 mm is first laminated onto a plastic foil, coated with a light-sensitive photoresist and illuminated through a positive film. The picture on this film is the subsequent form of the coil. The chip transponder is then attached to the same foil using soldered connections. No additional capacitor is used. The coil size is limited due to maximum dimension of the tag: 48x82 mm. The transponder antenna layout is depicted in figure 7.

The equivalent circuit diagram for this antenna and a Philips transponder connected to the antenna pads is presented in figure 8. The total capacitance  $C_t$  is composed by the internal capacitor of transponder chip and the parasitic capacitor (coil and connections). The load resistor is the equivalent input resistor of the transponder.

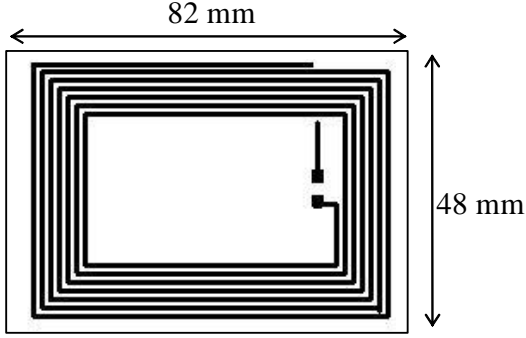

**Figure 7.** The transponder antenna layout

The resonant frequency of the parallel resonant circuit can be calculated with:

$$f_0 = 1/2\pi\sqrt{L_c C_t} \quad (1)$$

According with [1], the minimum field strength  $H_{\min}$  at maximum distance  $x$  between transponder and reader, at which the supply voltage for chip transponder  $u_T$  is just high enough for operation is called the interrogation field of the transponder and can be calculated with:

$$H_{\min} = \frac{u_T \sqrt{\omega^2 \left( \frac{L_c}{R_L} + \frac{R_c}{\omega_0^2 L_c} \right)^2 + \left( \frac{\omega_0^2 - \omega^2}{\omega_0^2} + \frac{R_c}{R_L} \right)^2}}{\omega \mu_0 A N} \quad (2)$$

where  $\omega_0 = 2\pi f_0$  from relation (1),  $A$  is the antenna area and  $N$  is the number of the coil turns. For the transponder coil proposed with  $N=7$ ,  $A=45 \times 76 \text{ mm}^2$ ,  $R_c=2\Omega$ ,  $R_L=1.5\text{k}\Omega$ ,  $L_c=5\mu\text{F}$  ( $C_t=28\text{pF}$ ), using the Philips SLI ICODE transponder with  $u_T=5\text{V}$ , the interrogation sensitivity versus frequency is presented in figure 9.

Obviously, the minimum value for  $H_{\min}$  is obtained for  $\omega = \omega_0$ . We have to note that due to component tolerances, the resonant frequency is always changed (resonance splitting) and the minimum field strength  $H_{\min}$  necessary for chip operation is increasing accordingly.

The efficiency of power transfer between the reader antenna coil and the tag coil is proportional to the operating frequency  $f$ , the number of coil turns  $N$ , the area  $A$  enclosed by the tag coil, the presentation angle of the two coils relative to each other, and the distance between these two coils. Maximum power transfer occurs when the two coupled coils

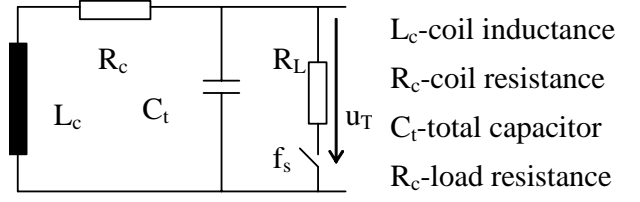

**Figure 8.** Equivalent circuit for transponder

(from reader and transponder) are placed or aligned in the same plane. As the label is rotated with respect to the transmit coil, the coupling is reduced by the cosine of the angle of rotation. Another measure of the voltage and current step-up obtained at resonant frequency in the resonant circuit is the quality factor  $Q$  [1,5]:

$$Q = 1 / \left( \frac{R_c}{\omega L_c} + \frac{\omega L_c}{R_L} \right) \quad (3)$$

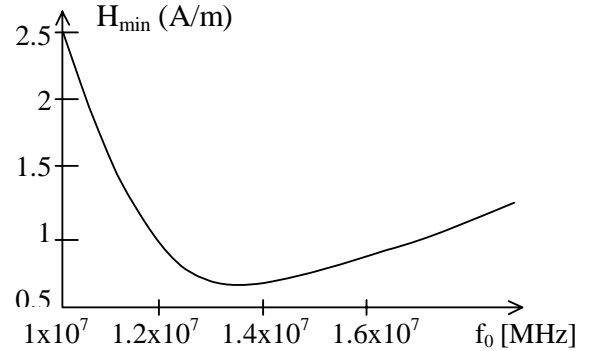

**Figure 9.**  $H_{\min}$  versus resonant frequency

The power transfer efficiency are increasing with  $Q$  also but, in practice,  $Q$  will not exceed 80 to avoid the undesirably attenuation of sideband (data transmission between transponder and reader is using amplitude modulation and the useful data is contained in two sidebands).

For a chosen reader antenna, a maximum area  $A$  (due to tag dimensions) and a limited number  $N$  (if  $N$  increase,  $A$  will decrease) the operating range cannot exceed 30 cm anyway. However, a good design will save the reduction of the operational range due to unmatched in resonant frequency or a low  $Q$  factor.

The inductance  $L_c$  for a coil with a shape like in figure 7 (N-turn planar spiral coil) can be calculated using the formula [6]:

$$L_C = L_0 + M_+ - M_- \quad (4)$$

where  $L_0$  is the sum of self inductances of all straight segments,  $M_+$  is the sum of so-called positive mutual inductances and  $M_-$  is the sum of so-called negative mutual inductances. The mutual inductance is the inductance that is resulted from the magnetic fields produced by adjacent conductors. The mutual inductance is positive (will be added to  $L_0$  in (4)) when the directions of current on conductors are in the same direction, and negative (will be decreased from  $L_0$  in (4)) when the directions of currents are opposite directions.

The coil layout from figure 7 contain 28 straight segments ( $N = 7$  turns) and then, the total inductance  $L_0$  from (4) can be calculated with:

$$L_0 = \sum L_i \quad i = 1 \dots 28 \quad (5)$$

The inductance of one straight segment  $i$  can be calculated with [6]:

$$L_i = 2l \left\{ \ln \frac{2l}{w+t} + 0,50049 + \frac{w+t}{3l} \right\} \quad (nH) \quad (6)$$

where  $l$  is the length (inch),  $t$  is the thickness (inch) and  $w$  is the width (inch) of the segment.

The mutual inductance between two parallel conductors is a function of the length of the conductors and of the geometric mean distance between them and can be calculated, according with [6] with:

$$M_{j,k} = M_{k+p} - M_{k-p} \quad (7)$$

where

$$M_{k \pm p} = 2l_{k \pm p} \ln \left\{ \left( \frac{l_{k \pm p}}{d_{j,k}} \right) + \left[ 1 + \left( \frac{l_{k \pm p}}{d_{j,k}} \right)^2 \right]^{1/2} \right\} - \left[ 1 + \left( \frac{d_{j,k}}{l_{k \pm p}} \right)^2 \right]^{1/2} + \left( \frac{d_{j,k}}{l_{k \pm p}} \right) \quad (8)$$

where  $l_{k+p}$  is sum/difference between  $k$  and  $p$  segment lengths and  $d_{j,k}$  is the distance between central axes of these segments (figure 10).

For  $N = 7$  turns there are 84  $M_+$  and 156  $M_-$  mutual inductances to be calculated and we have been used a dedicated software program in order to calculate them.

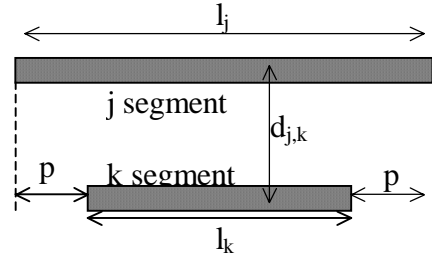

**Figure 10.** Two conductor segments for mutual inductance calculation

The width  $w$  and distance  $d_{j,k}$  were adjusted to get a total  $L_C$  in respect with relation (1), taking in consideration that the  $C_t = 28$  pF for the transponder Philips SLI ICODE and coil format chosen. The thickness for coil turns is  $t=50\mu\text{m}$ . From relation (1), the necessary  $L_C$  to match the resonant frequency with the transmitted frequency  $f_0$  is  $L_C = 4,92 \mu\text{H}$  and this value can be obtained using  $w = 0,6$  mm and  $d_{j,k} = 0,8$  mm.

### 6. 13,56 MHz system versus 125/134 kHz system

In order to compare the performances between the new 13,56 MHz RFID system and the old 125 kHz RFID system we used the same animal tag format and a HITAG 3 (the newest version) 125 kHz transponder from Philips. A TEK Protégé 125 kHz and TEK Protégé 13,56 MHz portable readers have been used to read/write data in transponders. During the test, the two coupled coils (from reader and transponder) were placed in the same plane.

The compared performances for these two RFID systems are presented in table 1. The results are the average of 50 measurements with different transponders but the same readers. Two procedures were imposed for read time and write time tests:

*Procedure a)* - the transponder was not activated one hour at least before test;

*Procedure b)* - the transponder was activated (read) 1 minute (or about) before test.

The b) procedure is necessary because, in practice, it's usually to write data on transponder but after identification (a read procedure).

Table 1

	Unit	125 kHz RFID system	13,56 MHz RFID system
Read time - a) procedure	sec	7,5	4,5
Read range - a) procedure	cm	1,5	25
Write time - a) procedure	sec	15	6
Write range - a) procedure	cm	1	18
Read time - b) procedure	sec	5	2,5
Read range - b) procedure	cm	2	28
Write time - b) procedure	sec	13	4
Write range - b) procedure	cm	1,5	20

All transponders contain the same quantity of data in read procedure and the same animal data was transmitted to the tag during write procedure.

### 7. Benefits of 13, 56 MHz RFID system

The most important benefits for 13,56 MHz system is the possibility to access data directly from the transponder attached to the animal without having to contact the central database. Thus, the operator (veterinary) can access in field the animal ID data to get the origin, diseases and treatments histories, vaccines, etc. The operator can also add new data to the tag. The management team will have a modern tool to have a multiple inventory locations, the purchase/selling information, birth/death record, etc. Another major benefit could be the introduction of the system in the processing industry, where the origin of the processed meat could be easily traced.

Other benefits are:

- frequency band available worldwide as an ISM (Industrial Scientific Medical) frequency and no user licenses for reader systems required;
- ISO 15693 standardization for data transfer;
- robust reader-to-tag communication and excellent immunity to environmental noise and electrical interference;
- good data transfer rate, larger read/write range and shorter reading/writing procedure;
- on-chip capacitors for tuning and low cost antenna coil manufacturing;
- cheap transponders involved (0,1 USD/pcs. for large volume production);

### 8. Conclusions

The new 13,56 MHz RFID transponder based system for animal identification and tracking introduce a considerable increasing in the operational range (read/write range) versus the currently barcode and 125/134 kHz transponder based systems. The read and write time are also reduced. The system proposed is mainly suitable for mobile readers with or without wireless communication with a central database. This system, together with the software livestock management program can be introduced in large animal farms, with multiple locations, for a modern livestock management.

### References

- [1] Finkenzeller, Klaus RFID Handbook, (2003) *Fundamentals and Applications in Contactless Smart Cards and Identification*, second edition ISBN: 0470844027.
- [2] \*\*\* *Transponder News, Magnetic coupled transponder systems*,  
[www.transpondernews.com/magnetic.html](http://www.transpondernews.com/magnetic.html).
- [3] \*\*\* *Motorola*, (1999) BiStatix Technology, A Whitepaper, version 4.1.
- [4] \*\*\* *I CODE SLI Smart Label IC, SL2 ICS20, Functional Specification*, Philips, 2003
- [5] \*\*\* *Overview of inductively coupled RFID Systems*, 2003, Tutorial, Rafsec.
- [6] H.M. Greenhouse (1974) *IEEE Transaction on Parts, Hybrid and Packaging*, Vol. PHP-10, No.2.